



# TX3340

---

## REMOTE MIC UHF RADIO

---



**AUSTRALIA**  
Design & Manufacture

**INSTRUCTION MANUAL**

## CONTENTS

INTRODUCTION .....	3	USING SELCALL .....	9
EMERGENCY CHANNELS .....	3	Entering a Selcall Ident .....	9
TELEMETRY CHANNELS .....	3	Sending Selcall .....	9
FEATURES .....	3	Call Acknowledge .....	9
GENERAL OPERATION .....	4	Storing Selcall Idents .....	9
MC520B Microphone/Controller .....	4	Recalling Selcall Idents from Memory .....	10
Function Key .....	4	Naming Your Selcall Idents .....	10
Volume Key .....	4	Displaying ALPHA Names .....	10
Selecting Channels .....	4	Entering and Storing a Selcall Name .....	10
Keylock Feature .....	4	Changing Your Own Selcall Ident .....	11
Transmitting .....	4	To Exit 'Call To' Mode .....	11
Squelch Control .....	4	Receiving Selcalls .....	11
Squelch Sensitivity .....	5	Cancelling the Selcall Alert .....	11
Priority Channel .....	5	Quiet Mode .....	11
Duplex Operation .....	5	Scanning in Quiet Mode .....	12
CTCSS & DCS .....	5	GROUP CALLING .....	12
Selecting the CTCSS or DCS Tone .....	6	Programming and Sending Group Calls .....	13
Enabling CTSS/DCS on a Channel .....	6	MENU SETTINGS .....	14
Disabling CTCSS/DCS on a Channel .....	6	Setting the Squelch Sensitivity .....	14
Monitoring the Channel .....	6	CTCSS & DCS .....	14
SCANNING .....	6	Backlighting .....	15
Scan Groups .....	6	Display Colour .....	15
Selecting a Scan Group .....	6	Battery / S-Meter / ALPHA Selection .....	15
Programming Scan Channels .....	6	Beep .....	15
OPEN SCAN MODE .....	7	INSTALLATION .....	15
Using Scan in the Open Scan Mode .....	7	Antenna Installation .....	16
GROUP SCAN MODE .....	7	Noise Suppression .....	16
Setting Up the Group Scan .....	7	DC Power Connection .....	18
Scanning in the Group Scan Mode .....	7	High Voltage Warning .....	18
Using Two Group Scan or Two Open Scan Modes .....	8	Antenna Connection .....	18
SELECTIVE CALLING .....	8	CTCSS TONE FREQUENCY CHART .....	19
Selcall Identification Number .....	8	DCS TONE CHART .....	20
Selcall Ident Names .....	9	UHF CB OPERATING FREQUENCIES .....	21
Quiet Mode (Q) .....	9	SPECIFICATIONS .....	22
Selcall Memories .....	9	SC CONTRACT WARRANTY .....	23
		GME After Sales Service .....	23

## ACCESSORIES SUPPLIED

- Main Radio Unit
- DC Lead
- Mounting Cradle
- Screw Pack
- Instruction Manual
- If any items are missing or damaged, please contact your retailer or place of purchase.*
- MC520B LCD Microphone
- Microphone Clip

## INTRODUCTION

Your GME TX3340 radio is Australian designed and built and is the most advanced UHF Citizen Band radio available.

The TX3340 combines the very latest in electronic hardware with the most up-to-date computer aided design and manufacturing techniques to produce an extremely compact mobile radio with outstanding specifications and performance.

The TX3340 with its Controller Microphone is designed for unobtrusive mounting in modern vehicles. The radio case with its built-in loud speaker and extremely small size can be mounted in almost any convenient location.

**NOTE:** The Citizens Radio Service is licensed in Australia by ACMA Radiocommunications (Citizens Band Radio Stations) Class License and in New Zealand by MED General User Radio License for Citizens Band Radio and operation is subject to conditions contained in those licenses.

## EMERGENCY CHANNELS

The ACMA has allocated channels 5/35 for emergency use only. Channel 5 is the primary Simplex Emergency Channel. Where a Channel 5 repeater is available, you should select Duplex on CH 5.

**Note:** Channel 35 is the input channel for the Channel 5 repeater therefore Channel 35 should also not be used for anything other than emergency transmissions.

## TELEMETRY CHANNELS

ACMA regulations have allocated channels 22 and 23 for telemetry-only applications and have prohibited the transmission of speech on these channels. Consequently the TX3340 has a transmit inhibit applied to channels 22 and 23.

## FEATURES

- **Controller Microphone:** Complete control of the radio from the microphone simplifies installation.
- **Microprocessor Controlled Frequency Synthesiser:** Allows user programmable control of scanning, channel memories and selected feature options.
- **Programmable Scan Function:** Scans the programmable UHF CB channels with both Group and Open scan functions available.
- **Individually Programmable DUPLEX function:** User selectable for only those individual channels in your area that have repeaters, leaving the others free for use as extra simplex channels.
- **Priority Channel:** A user programmable priority channel feature allows your working or local repeater channel to be instantly recalled at the press of a button.
- **High Contrast Liquid Crystal Display:** Fully detailed LCD provides a visual indication of the selected channel and all selected functions at a glance. Backlit for viewing at night.
- **In-Built Selcall:** Selective Calling with five digit ANI and fully user-adjustable 5 tone transmitted Selcall Ident. Also allows naming of Idents for easier caller identification.
- **Quiet Mode:** Selectable on individual channels, Quiet mode prevents incoming signals from being heard on selected channels unless preceded by your Selcall code.
- **CTCSS & DCS:** A built-in Continuous Tone Coded Squelch and Digital Coded Squelch System option provides quiet channel operation.
- **Overvoltage Protection:** Special overvoltage detection circuitry protects the radio and warns of excessive voltage conditions by flashing the display.
- **Surface Mount Technology:** The very latest surface mount component types, design and assembly techniques and quality control procedures are used to ensure the highest performance and reliability.
- **Designed and Manufactured in Australia:** The TX3340 has been totally designed and manufactured in Gladesville N.S.W. to meet the demanding needs of the Australian community.

## GENERAL OPERATION

### MC520B MICROPHONE/CONTROLLER

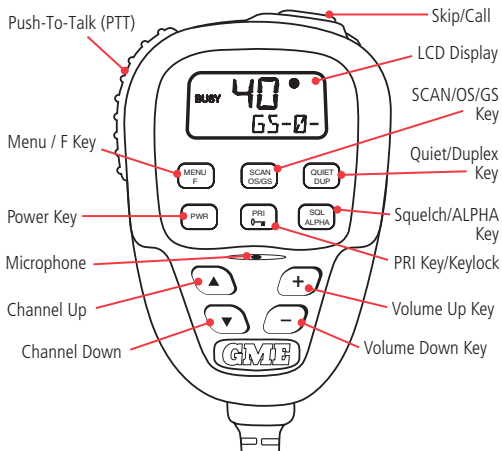

### FUNCTION KEYS

There are several keys beneath the microphone controller's display that have both primary and secondary functions. Their primary functions are printed in Black while their secondary functions are printed in Red.

#### To access the primary functions

Simply press the required key. e.g. To control the Squelch, briefly press the **SQL** key.

#### To access the secondary functions

Press the red **F** key followed immediately by the required red coloured key.

**Note:** If the secondary key is not pressed within 10 seconds the **F** key selection will be cancelled.

### VOLUME KEY

Press the **+** key to increase the volume and the **-** key to decrease the volume.

**Note:** At minimum volume setting there is still sufficient volume to be heard in a quiet cabin environment.

### SELECTING CHANNELS

Press the **▲** or **▼** keys to step upwards or step downwards one or more channels.

### KEYLOCK FEATURE

The **0** key locks the keys on the microphone to prevent unintentional key presses from altering your TX3340 settings. While the keys are locked, only the **PTT** (Push-To-Talk), **SQL** key, on/off, Volume keys, the **F** key and the **0** (Keylock) key will continue to function.

#### To lock the keys

Briefly press the **F** key, then press and hold the **0** key until a high beep is heard. 'LOCK' will appear briefly on the display.

#### To unlock the keys

Briefly press the **F** key, then press and hold the **0** key until a low beep is heard. 'UNLOCK' will appear briefly on the display.

### TRANSMITTING

To transmit, press the **PTT** button. Hold the microphone about 5-8 cm from your face and speak at a normal voice level. The microphone is quite sensitive so it is not necessary to raise your voice or shout. Release the **PTT** when you have finished talking.

**IMPORTANT:** Always listen to ensure the channel is free before transmitting.

### SQUELCH CONTROL

Squelch control is used to eliminate the background noise when there are no signals present. The TX3340 features a preset Squelch system. The Squelch sensitivity has been factory set to provide optimum performance in most environments, however the sensitivity can be altered by the user if required, to suit varying environmental situations.

The Squelch can be opened or closed with the **SQL** key. When the Squelch is open, the receiver's background noise can be heard and 'BUSY' is displayed. When the Squelch is closed, the receiver remains quiet when there are no signals present but an incoming signal will override the squelch and be heard in the speaker.

#### To open the Squelch

Briefly press the **SQL** key. A low beep will be heard. If there are no signals present you will hear the receiver's background noise.

#### To close the Squelch

Briefly press the **SQL** key again. A high beep will be heard and the receiver will become quiet.

**Note:** If an incoming signal is very weak and is close to the minimum squelch level, it may become broken or 'chopped' by the squelch action. To prevent this, simply open the Squelch to allow the signal to be heard clearly. Alternatively you can reduce the Squelch sensitivity as described below.

## SQUELCH SENSITIVITY

The sensitivity of the Squelch to incoming signals can be set to suit your operating environment. For example, excessively noisy environments may cause the squelch to open on local noise. The TX3340 has nine (9) preset Squelch sensitivity settings that can be selected using the **MENU** function.

To adjust the pre-set Squelch sensitivity, please refer to the **MENU SETTINGS** on page 14.

## PRIORITY CHANNEL

The Priority Channel feature allows you to store one of the channels as a Priority Channel that can be instantly recalled at the press of a key. This can be used to provide instant access to your working channel or your local repeater channel.

### To store a Priority Channel

1. Select the required channel.
2. Press and hold the **PRI** key until a high beep is heard. The selected channel will be stored.

### To Recall a Priority Channel

Briefly press the **PRI** key. The radio will switch straight to the selected Priority Channel. Any active functions (such as scanning or Quiet) will be cancelled.

## DUPLEX OPERATION

Duplex operation allows the radio to transmit on a different frequency to that which it receives. This allows operation through repeater stations. Repeaters automatically re-transmit your signal over a wider area, providing greatly increased range.

### Simplex/Duplex Range Comparison

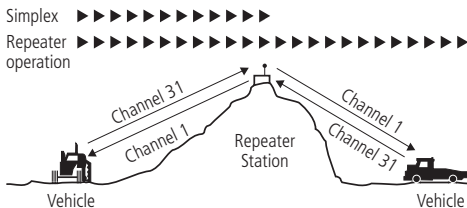

Duplex operation operates only on channels 1-8. When duplex is selected on these channels, the radio receives on that channel but actually transmits 30 channels higher.

e.g.

<b>Channel Selected</b>	1	2	3	4	5*	6	7	8
<b>Receive Channel</b>	1	2	3	4	5*	6	7	8
<b>Transmit Channel</b>	31	32	33	34	35*	36	37	38

\* Emergency Channel only

The TX3340 allows you to select Duplex operation individually on each channel.

### To select Duplex on individual channels

1. Select the required channel 1-8
2. Briefly press the **F** key then press the **DUP** key. 'DUP' will appear on the display accompanied by a high beep.

### To remove Duplex from a channel

1. Select the required channel 1-8. 'DUP' will be visible on the display.
2. Briefly press the **F** key then press the **DUP** key. 'DUP' will disappear from the display accompanied by a low beep.

## CTCSS & DCS

CTCSS (Continuous Tone Coded Squelch System) and DCS (Digitally Coded Squelch) are Squelch quieting systems that allow several groups of users to share the same channel without disturbing each other. They use a preset sub-audible (very low frequency) tone to open and close the Squelch on your radio. There are three optional tone sets available, comprising 38, 50 or 104 user-selectable tones. The system applies a continuous low-level tone to your transmission and uses a matching tone decoder to control your receiver's Squelch. With CTCSS or DCS enabled, the channel remains quiet to all incoming signals unless they carry the correct tone. When a transmission with the correct tone is received, the Squelch opens and remains open for as long as the signal is present. When the transmission ends, the channel becomes quiet again. Transmissions that do not use the correct tone will not be heard.

The TX3340 allows CTCSS or DCS to be enabled or disabled on individual channels.

**Note:** The CTCSS/DCS tone you select will be used for all CTCSS/DCS enabled channels in your radio.

## SELECTING THE CTCSS OR DCS TONE

To pre-select the CTCSS or DCS tone on your radio, please refer to the **MENU SETTINGS** on page 14.

### ENABLING CTCSS/DCS ON A CHANNEL

Once a CTCSS/DCS tone has been selected, it can be enabled on individual channels.

1. Press the ▲ or ▼ keys to select the required channel.
2. Press and hold the **SQL** key. A high beep will be heard and 'SILENT' will appear on the display.

You may activate CTCSS/DCS on as many channels as you wish except channel 5 which is designated for emergency use.

### DISABLING CTCSS/DCS ON A CHANNEL

Repeat steps 1 and 2 above. A low beep will be heard and 'SILENT' will disappear from the display.

**Note:** You will not be able to activate CTCSS/DCS if the CTCSS/DCS tone is set to 'OF'.

Please see the **CTCSS and DCS Tone Frequency Charts** on pages 19 and 20.

### MONITORING THE CHANNEL

It is useful to be able to temporarily open your radio's Squelch to allow you to listen for signals from other CTCSS/DCS users outside your group. Because their CTCSS/DCS tone is different to yours, your Squelch would normally remain closed, preventing you from hearing them. You can use the **SQL** key to open the Squelch and listen to the channel to check that it is clear before transmitting. This will help prevent you from accidentally transmitting over the top of others.

#### To monitor the channel

Briefly press the **SQL** key. If there are no signals present, you will hear the usual hiss of an empty channel. Press the **SQL** key again to restore the Squelch to its previous setting.

## SCANNING

The TX3340 has a SCAN function that allows groups of user programmable channels to be scanned for signals. Channels can be scanned at 20 channels per second. When a signal is found, scanning will pause on that channel to allow the signal to be heard, then resume scanning when the channel is clear again.

## SCAN GROUPS

The TX3340 features two scan groups by default - Open Scan and Group Scan.

### Open Scan

Allows any of the installed channels to be scanned for activity. If a busy channel is found, scanning will pause to allow the signal to be heard. Once the channel has been clear for 5 seconds, scanning will resume automatically.

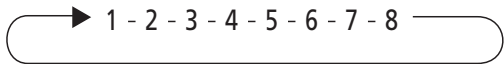

e.g. Scanning channels 1-8 in Open Scan.

### Group Scan

Also allows any of the installed channels to be scanned for activity, but in addition, it inserts your Priority Channel into the scan sequence. This means that your Priority Channel will be monitored regularly while scanning to ensure that no calls are missed. Any signals received on your Priority Channel will take precedence over any signals received on the other channels.

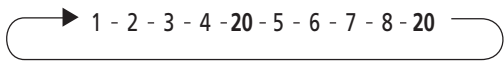

e.g. Scanning channels 1-8 with Priority Channel 20 in Group Scan.

## SELECTING A SCAN GROUP

### To pre-select a scan group

The radio is initially set to Open Scan mode. To toggle between Scan Groups, press the **F** key followed by the **OS/GS** key. 'OPEN' or 'GROUP' will be displayed briefly to confirm your selection.

## PROGRAMMING SCAN CHANNELS

Your TX3340 is supplied with all 40 UHF CB channels programmed into the Open Scan memory. Any channels not needed, can be removed if required. The Group Scan memory is empty by default and you will need to add channels to it before use.

### To add or remove channels from either scan memory

1. Ensure that the radio is not already scanning. If it is, briefly press the **SCAN** key to cancel the scan function.
2. Ensure you have the required scan group pre-selected.
3. Select the required channel by using the ▲ or ▼ keys

- If 'M' is visible to the right of the channel number, the selected channel is already in the scan memory.
- If 'M' is not visible, then the selected channel is not in the memory.
- To add or remove the selected channel, press and hold the **SCAN** key for a few seconds until a beep is heard.

4. Repeat step 3 to add or remove other channels in the scan memory.

### To start scanning

To begin scanning, briefly press the **SCAN** key. A high beep will be heard, 'SCAN' will appear in the display and the radio will begin scanning. In addition the selected scan group will be displayed below the channel number.

**Note:** If there is only one channel programmed into the Open Scan memory or none in the Group Scan memory, a long low beep will be heard when you press the **SCAN** key and the command will be ignored.

### To stop scanning

To cancel the scan, briefly press the **SCAN** key. A low beep will be heard and 'SCAN' will disappear from the display.

## OPEN SCAN MODE

### USING SCAN IN THE OPEN SCAN MODE

- If a busy channel is found, scanning will pause on that channel to allow the signal to be heard and will remain there for as long as the channel remains busy. Once the channel has been clear for 5 seconds, scanning will resume automatically.
- If your radio pauses on a busy channel and you don't wish to listen to that conversation, briefly press the **SKIP** button on the microphone. The radio will skip over that channel and resume scanning from the next channel in the sequence.
- If your radio is paused on a busy channel and you wish to remain there, briefly press the **SCAN** key. The radio will exit Scan mode and remain on the busy channel.
- To transmit while paused on a busy channel, wait until the channel is free, then press the **PTT** button. The radio will exit Scan mode and remain on the busy channel. You can now converse on that channel in the usual way. When you have finished your conversation, briefly press the **SCAN** key to resume scanning.

- If your radio is scanning and you need to use your Priority Channel (for an urgent call or an emergency), briefly press the **PRI** key. The Scan mode will be cancelled and the radio will jump straight to the Priority Channel.

**Note:** In Open Scan mode your TX3340 will not allow you to transmit while it is scanning. If the **PTT** button is pressed while scanning, the radio will give a low beep and will ignore the command. Your radio will only transmit while scanning is paused on a busy channel.

## GROUP SCAN MODE

Group Scan allows you to transmit and receive normally on your Priority (working) Channel, while continuing to scan several other channels. The receiver will scan the other channels **ONLY WHILE THERE ARE NO SIGNALS ON THE PRIORITY CHANNEL**.

If a signal appears on the Priority Channel it will override any signals being received on any of the other channels. In addition, if you press the **PTT** button at any time, the radio will transmit on the Priority Channel in the usual way.

### SETTING UP THE GROUP SCAN

Referring to the appropriate sections of this manual:

1. Pre-select the Group Scan mode.
2. Store your preferred working channel into the Priority Channel memory (see **Priority Channel**).
3. Program the required 'other' channels into your Group Scan memory (see **Programming Scan Channels**).

### SCANNING IN THE GROUP SCAN MODE

To scan in the Group Scan mode, briefly press the **SCAN** key. A high beep will be heard, 'SCAN' will appear in the display and the radio will begin scanning.

**Note:** If there are no channels programmed in the Group Scan memory when you press the **SCAN** key (or there is only one channel programmed and it is the same as the Priority Channel), a low beep will be heard and the command will be ignored.

When scanning, the TX3340 scans all the channels programmed into the Group Scan memory, with the Priority Channel being scanned after every fourth channel (retailer programmable option, if you require different timing for your priority channel, please contact your retailer).

- If a signal appears on the Priority Channel - at any time - the receiver will switch straight to the Priority Channel and will stay there for as long as the channel is busy. During this time you can transmit on the Priority Channel in the usual way. Once there has been no activity for 5 seconds, the radio will resume scanning the other channels.
- If a signal appears on one of the other channels, scanning will pause on that channel and will remain there while the channel is busy, as long as there are no signals on the Priority Channel. During this time the receiver will continue to check the Priority Channel for signals every 2 seconds, resulting in a series of small 'breaks' in the reception of the paused channel. Once there has been no activity on any channel for 5 seconds, the radio will resume scanning.
- If your radio pauses on a busy channel and you don't wish to listen to that conversation, briefly press the **SKIP** key on the microphone. The radio will skip over that channel and resume scanning from the next channel in the sequence.
- If your radio is paused on a busy channel and you wish to remain there, briefly press the **SCAN** key. The radio will exit Scan mode and remain on the busy channel.

**Note:** The radio will no longer be monitoring the Priority Channel (unless it is the same as the busy channel). To resume scanning, press the **SCAN** key again.

- To transmit on the Priority (working) Channel AT ANY TIME, simply press the **PTT** key while the radio is scanning. The radio will switch straight to the Priority Channel. When you have finished your conversation and there has been no further activity on the Priority Channel for 5 seconds, the radio will resume scanning the other channels.
- To go directly to the Priority Channel, briefly press the **PRI** key. The radio will exit Scan mode.

## USING TWO GROUP SCAN OR TWO OPEN SCAN MODES

If you prefer, the TX3340 can be re-programmed to have two Group Scan modes or two Open Scan modes instead of one of each.

For example there may be applications where you have no need to scan the Priority Channel and would prefer to have two separate Open Scan modes. Alternatively you may have applications where you prefer to have two Group Scan modes with different Scan groups in each.

Your TX3340 can be retailer programmed to convert the Group Scan mode into a second Open Scan mode and vice versa. If you would prefer to have two Group Scan or two Open Scan modes, you should contact your GME retailer to arrange for this feature to be enabled (when using two Group Scan modes the Priority Channel will be the same channel for both scan groups).

When the second Open or Group Scan mode is enabled, the resulting two Scan modes become Scan 1 and Scan 2.

### To select the required scan mode

Press the '**F**' key followed by the **OS/GS** key. 'Scan 1' or 'Scan 2' will be displayed to confirm your selection. When enabled, the two scan modes will be identical in operation.

**Note:** Enabling or disabling the second Open or Group Scan mode is not a user selectable option. Once enabled by your GME retailer, the changed Scan mode becomes a permanent part of the TX3340's features and replaces the standard Scan selection. If you find later that you need the original Group or Open Scan function re-enabled, you will need to return your TX3340 to your retailer for re-programming.

## SELECTIVE CALLING

Your TX3340 has a Selective Calling system known as Selcall that operates like a telephone. Your radio is pre-programmed with its unique Selcall Identification Number. If this number is called by another radio, your TX3340 will beep to alert you. If you do not want to hear any other activity while waiting on a channel, you can select QUIET mode. This will force the radio to remain quiet to all incoming signals until your Selcall number is called.

Your TX3340 will allow you to store up to ten (10) of your most frequently called Selcall numbers. Each number can be labelled with a 5-letter name for easy identification.

### SELCALL IDENTIFICATION NUMBER

Your TX3340 is factory programmed with its own unique Selcall Identification Number (Ident). This number identifies your radio from others in your area. Your radio's own Selcall Ident will be displayed for a few seconds, directly beneath the channel display, when you first turn the radio on.

You will need to make your Ident known to anyone who may need to call you using Selcall. Whenever your TX3340 hears a Selcall signal, it compares the incoming Ident with its own. If the two

Identifiers match, the radio knows it is being called and sounds an alarm to alert you, otherwise the call is ignored.

**Note:** Although your radio's Selcall Ident is pre-programmed at the factory, you can change it if required. See **CHANGING YOUR OWN SELCALL IDENT** on page 11.

## SELCALL IDENT NAMES

When storing Selcall Identifiers, the TX3340 allows you to add a 5 character name to each one, making it easier to identify whose Ident you are recalling from the memory. In addition, if an incoming Selcall matches one of the Identifiers stored in the memory, the name can be displayed to make it easier for you to identify the caller.

## QUIET MODE

Your TX3340 can be set to monitor signals on a busy channel but remain quiet unless it receives its own Selcall Ident. In this way, you won't be disturbed unless someone calls you. When a signal containing your Selcall Ident is received, QUIET mode is deactivated and an alarm sounds to alert you to the call. You can then converse normally on the channel.

QUIET mode operation is described later in this manual.

**Note:** QUIET mode overrides the normal Squelch system to ensure that the radio remains quiet even when the channel is busy. When QUIET is set, you may see the 'BUSY' icon appear on the display indicating the channel is being used. However, unless someone transmits your Selcall Ident, nothing will be heard in the speaker.

You can activate QUIET mode on individual channels i.e. some channels can be set to remain quiet while others can remain open to all incoming signals.

**TIP:** Setting QUIET mode is not mandatory. You can still use Selcall on any channel whether the QUIET mode is set or not.

## SELCALL MEMORIES

Your TX3340 is fitted with one Call memory and 10 Selcall Ident memories. The 10 Selcall Ident memories are used to store frequently used Selcall Identifiers. The additional Call memory holds the Ident you last sent or received. The memories can be viewed by briefly pressing the **CALL** key. The initial memory displayed is the Call memory. Pressing the ▲ or ▼ keys will step through the other 10 Selcall storage memories in sequence. Selcall memories are labelled 'c0' to 'c9'.

## USING SELCALL

**Note:** The ACMA requires that cumulative Selcall transmissions should not exceed 3 seconds in any 60 second period. To meet this requirement with your TX3340 you should not send any more than 3 Selcall transmissions per minute.

## ENTERING A SELCALL IDENT

1. Press the **CALL** button. 'CALL TO' is displayed, along with the last sent or received Selcall Ident. The radio is now in 'CALL TO' mode.

**Note:** If an ALPHA label is displayed you will need to switch to NUMERIC Mode. To toggle between ALPHA mode and NUMERIC mode, briefly press the **F** key followed by the **ALPHA** key.

2. Enter the required Selcall Ident as follows:

- Press and hold the **PRI** key until the radio beeps. The right-hand digit of the Selcall Ident will flash.
- Press the ▲ or ▼ keys to select the required number in the flashing digit position.
- Briefly press the **PRI** key again to select the next digit position.
- Repeat steps (b) and (c) to enter all 5 digits as required. The Selcall number is now ready to send.

## SENDING SELCALL

With the Selcall number displayed, press and hold the **CALL** button for 2 seconds. The radio will transmit the Selcall Ident.

**Note:** If the call is not sent within 10 seconds of entering the last Ident digit the call mode will time out and the radio will return to normal mode. To exit CALL TO mode without sending the Selcall briefly press the **CALL** button.

## CALL ACKNOWLEDGE

If your Selcall transmission is successful, the radio you called should respond with an 'acknowledge' signal - usually two quick beeps. This will confirm to you that the radio you called is now alerting its user to your signal.

## STORING SELCALL IDENTIS

Your TX3340 is fitted with 10 user programmable Selcall Ident memories, allowing you to store up to 10 frequently used Selcall Idents. The memories are accessed by pressing the **CALL** button, then the **▲** or **▼** keys to scroll through the memories. Ident memories are labelled 'c0' to 'c9'.

### To Store a Selcall Ident in memory

1. Press the **CALL** button to select the CALL TO mode. 'CALL TO' is displayed along with the last sent or received Selcall Ident.
2. Press the **▲** or **▼** keys to select the required Ident memory (locations 'c0' to 'c9').

**TIP:** If the radio displays letters instead of numbers in the Selcall Ident position, your radio is in ALPHA mode. To switch back to NUMERIC mode, briefly press the **F** key followed immediately by the **ALPHA** key. 'NUMER' will be displayed for a few seconds in the Ident position.

3. With the required memory location displayed, enter the Selcall ident as follows:
  - (a) Press and hold **PRI** key until the radio beeps. The right-hand digit of the Selcall Ident will flash.
  - (b) Press the **▲** or **▼** keys to select the required number in the flashing digit position.
  - (c) Briefly press the **PRI** key again to select the next digit position.
  - (d) Repeat steps (b) and (c) to enter all 5 digits as required.
  - (e) Now press and hold the **PRI** key. The entire Ident will flash for a few seconds then the radio will beep as the new Ident is stored.

## RECALLING SELCALL IDENTIS FROM MEMORY

1. Press the **CALL** button to select the CALL TO mode. 'CALL TO' is displayed along with the last sent or received Selcall Ident.
2. Press the **▲** or **▼** keys to select the required Ident memory in locations 'c0' to 'c9'.
3. When the required Selcall Memory is displayed, press and hold the **CALL** button to send the Ident.

## NAMING YOUR SELCALL IDENTIS

The TX3340 allows you to name each Selcall Ident using a 5 character ALPHA name. The name is stored in memory along with the Ident making it easier to identify whose Ident you are recalling from the memory. If an incoming Selcall matches one of those in

your radio's memory, the name can be displayed instead of the Selcall Ident.

## DISPLAYING ALPHA NAMES

### To display the Selcall's ALPHA Name

You must have the radio's ALPHA display mode selected.

### To toggle the ALPHA display mode

Briefly press the **F** key followed by the **ALPHA** key. 'ALPHA' or 'NUMER' will be displayed for 2 seconds below the channel display to indicate the selected mode.

**TIP:** The normal channel display may give no indication of which display mode is selected. The selected mode will only become obvious when displaying Idents.

## ENTERING AND STORING A SELCALL NAME

**Note:** You should first store the required Ident in memory as described above under **Storing Selcall Idents**.

1. Ensure the ALPHA mode is selected (briefly press the **F** key followed by the **ALPHA** key to toggle ALPHA mode).
2. Briefly press the **CALL** button. The CALL TO mode will be selected and the last-sent Selcall memory location will be displayed.
3. Press the **▲** or **▼** keys to select the required Selcall memory (locations c0 to c9). If no ALPHA name has been programmed for that memory the radio will probably display '- - - -' otherwise it will display the last ALPHA name programmed into that memory.
- 4 With the required memory location displayed, enter the required ALPHA name as follows:
  - (a) Press and hold the **PRI** key until the radio beeps. The left-hand character of the ALPHA name will flash.
  - (b) Press the **▲** or **▼** keys to select the required letter in the flashing character position.

The following characters are available:

A B C D E F G H I J K  
L M N O P Q R S T U V  
W X Y Z  
0 1 2 3 4 5 6 7 8 9  
SPACE \* -

- (c) Briefly press the **PRI** key again to select the next character position.
- (d) Repeat steps (b) and (c) to enter all 5 characters as required.
- (e) Now press and hold the **PRI** key. The entire ALPHA name will flash for a few seconds then the radio will beep as the name is stored.

Repeat the procedure to add ALPHA names to any other Selcall Idents stored in memory.

---

## CHANGING YOUR OWN SELCALL IDENT

---

### To change your radio's own Selcall Ident:

---

1. Ensure your radio is in Numeric Mode (press **F**, **ALPHA** repeatedly until 'NUMER' is displayed).
2. Press the **CALL** button. 'CALL TO' is displayed along with the last send or received Selcall Ident.
3. Press the **▼** button. 'ID' will be displayed along with your radio's own Selcall Ident.
4. Press and hold the **PRI** key until the radio beeps. The right hand Selcall digit will flash.
5. Press the **▲** or **▼** buttons to select the required number in the flashing digit position.
6. Briefly press the **PRI** key again to select the next digit position.
7. Repeat steps 5. and 6. to change further digits in your Selcall Ident.

When you have the required Selcall Ident displayed, press and hold the **PRI** key until the radio beeps. The new Ident will be saved.

---

### TO EXIT 'CALL TO' MODE

---

While in the CALL TO mode, briefly press the **CALL** button. The radio will return to normal operation.

**Note:** The radio can be left in the ALPHA display mode so that an incoming Selcall matching one of those in the radio's memory will display the name associated with that Selcall Ident instead of the Ident itself. Any incoming Selcalls not matching those in the memory will display '-NEW-'. To display the Selcall Ident of that caller, briefly press the **F** key followed by the **ALPHA** key to return to the NUMERIC display mode.

---

---

## RECEIVING SELCALLS

---

When your TX3340 receives its Selcall Ident, an alarm will sound to alert you to the call. Initially the alarm will beep urgently at 2 beeps per second for around 10 seconds then slow to around 1 beep every 3 seconds if the call is not answered. It will then continue to beep indefinitely until you cancel it (the way your TX3340 handles the Selcall alert can be altered by your retailer).

In addition to the alarm, the words 'CALL FROM' will appear on the display along with the callers Selcall Ident or ALPHA name to inform you of the identity of the person calling.

---

### To switch between the Selcall Ident and the ALPHA name

---

Briefly press the **F** key followed by the **ALPHA** key.

---

## CANCELLING THE SELCALL ALERT

---

The following are the recommended methods:

---

### To cancel the alarm and talk on the channel

---

Press the **PTT** key and talk in the usual way. The alarm will be cancelled and the channel will be open for normal communication.

---

### To return the call

---

Press and hold the **CALL** key for a few seconds until the radio beeps. The callers Selcall will be sent to the caller.

---

### To cancel the alarm and listen on the channel

---

Briefly press the **QUIET** key (if QUIET has been activated). The alarm will stop beeping and the channel will remain open to any incoming signals.

---

## QUIET MODE

---

QUIET mode mutes the TX3340's receiver to prevent any incoming signals from being heard in the speaker until your Selcall Ident is received. In this way you can monitor a busy channel for personal calls without being disturbed by unwanted signals.

If your Selcall Ident is received, the radio will exit QUIET mode and all incoming signals will be heard in the speaker.

---

### Setting up QUIET Mode

---

To setup QUIET mode you must first 'tag' the channels that you want to stay quiet, then activate the QUIET mode. Once QUIET mode is activated, the channels you have tagged will remain quiet to all incoming signals unless your Selcall Ident is received. Channels not tagged will remain open to all signals and will operate normally.

---

### To tag individual channels for QUIET operation

---

1. Select the required channel by pressing the ▲ or ▼ keys.
2. Press and hold the **QUIET** key until the radio beeps. 'Q' will appear to the right of the channel display indicating the selected channel is now tagged for quiet operation.

---

### To remove the QUIET Tag from individual Channels:

---

1. Select a channel that has been tagged for quiet operation. 'Q' will be displayed.
2. Press and hold the **QUIET** key until the radio beeps. 'Q' will disappear indicating this channel is no longer tagged for quiet operation.

---

### Activating QUIET Mode

---

1. First, select a channel that has been tagged for quiet operation (you cannot activate quiet mode unless you have selected a 'tagged' channel). 'Q' will be displayed.
2. Now briefly press the **QUIET** key. 'QUIET' will appear on the display.

Now all channels that were tagged for quiet operation will be operating in the QUIET Mode.

---

### Deactivating QUIET Mode

---

1. Select any channel that has been tagged for quiet operation. 'Q' and 'QUIET' will be displayed.
2. Briefly press the **F** key followed by the **QUIET** key. 'QUIET' will disappear from the display and all channels that were tagged for quiet operation will now operate normally again.

---

### Receiving Signals in QUIET Mode

---

- If a normal signal is received on a QUIET channel, the channel will appear busy (the 'BUSY' indicator will be visible) but no sound will be heard from the speaker. This means you will not be disturbed by the signal.
- If a normal signal is received on an open channel (one that is not tagged with 'Q') the signal will be heard in the usual way.
- If a signal containing your Selcall Ident is received on any channel (Open or QUIET) QUIET mode will be cancelled and the alarm will beep to alert you to the call. In addition, the caller's Ident or ALPHA name will be displayed. All channels will now be open for normal transmission and reception.

If you wish to respond to the calling radio using Selcall, press and hold the **CALL** key for 1.5 seconds until the radio beeps. The callers Ident will be transmitted back to them causing the alarm in their radio to be activated.

---

### To cancel the alarm on your radio

---

Briefly press the **PTT** key.

---

### To return your radio to the QUIET mode

---

Briefly press the **QUIET** key. 'QUIET' will re-appear on the display.

---

### SCANNING IN QUIET MODE

---

The TX3340 will allow you to scan while QUIET mode is active. Using this feature you can monitor a group of quiet channels or a combination of Quiet and Open channels.

---

### To Scan in QUIET Mode

---

1. Pre-select the Scan mode. (Open/Group/Scan 1/Scan 2)
2. Select the channels you wish to scan and store them in the Scan memory.
3. From those channels, select the ones you wish to remain quiet and tag each one for QUIET operation.
4. Select a tagged channel and activate QUIET Mode (press the **QUIET** key).
5. Press the **SCAN** key. The radio will begin scanning and 'SCAN' and 'QUIET' will be displayed, indicating the radio is scanning in QUIET mode.

---

### Receiving Signals while scanning in QUIET Mode

---

- If a normal signal is received on an open channel, scanning will pause while the channel is busy and will resume scanning 5 seconds after the channel becomes clear. (If you were scanning in Group Scan mode, the radio may switch between the Open channel and the Priority Channel - this is normal).
- If a normal signal is received on a Quiet channel but your Selcall Ident is not detected, the signal will be ignored and scanning will continue.
- If a signal containing your Selcall Ident is received on any channel (Open or Quiet) both Scanning and QUIET modes will be cancelled and the receiver will stay on that channel. In addition, the alarm will beep to alert you to the call and the callers Ident or ALPHA name will be displayed. The channel will now be open for normal transmission and reception.

---

**TIP:** To ensure reliable Selcall detection when scanning in the QUIET mode, it is recommended that you restrict the number of channels in the Scan group to 4 or less.

---

## GROUP CALLING

The TX3340's Selcall system includes a Group Call function which allows you to call up to 1000 radios simultaneously. This can be useful in an emergency situation where you may need to transmit a message to a large number of radios in your group.

By default, your radio is factory-set to allow up to 10 radios to be called at once. If your application requires more, you can arrange for your retailer to re-program this option to allow 100 or 1000 radios to be called. The following description assumes the default Group Call setting of 10 radios.

The Group Call function works by allowing you to enter a special 'group code' into the last digit position of the Selcall Ident you are sending. The 'group code' appears as 'A' when displayed in the radio. When this 'group code' is received, it substitutes for all other numbers in the last digit position. As long as the first 4 digits of the Selcall you are sending match those of the radios you are calling, their Selcall alarm will be activated as if their full 5 digit Selcall Idents had been received.

To achieve this, the 10 radios you are calling must be programmed with sequentially numbered Selcall Idents.

e.g. 12330, 12331, 12332, 12333 . . .-> , 12339

- Transmitting the Selcall Ident 12331 will only activate the alarm in the radio with the Selcall Ident of 12331.
- Transmitting 1233A will activate the alarms in all radios with Idents 12330 through 12339 (a total of 10 radios).

If the radios in your fleet do not have sequentially numbered Selcall Idents and you want to make use of this function, you can arrange for your retailer to re-program the Selcall Idents in your radios.

### PROGRAMMING AND SENDING GROUP CALLS

The process for entering a Group Call Ident is the same as entering a normal Selcall Ident.

1. Press the **CALL** button. 'CALL TO' is displayed, along with the last sent or received Selcall Ident.
2. Enter the required Selcall ident as follows:
  - (a) Press the **PRI** key until the radio beeps. The right-hand digit of the Selcall Ident will flash.
  - (b) Press the **▲** or **▼** keys to select 'A' in the flashing digit position. This is the special code that will create the Group Call.
  - (c) Briefly press the **PRI** key again to select the next digit position.

- (d) Repeat steps (b) and (c) to enter the other 4 digits as required. The last digit will be set to 'A'.

Once the Ident has been entered you have 10 seconds to send it otherwise the CALL TO mode will be cancelled and the Ident you entered will be lost.

**Note:** Where your TX3340 allows it, programming group calls for 100 radios is identical except that you will need to select 'A' for the last two digits (e.g. 123AA). For 1000 radios you will need to select 'A' for last three digits (e.g. 12AAA).

e.g.

100 Radios Ident Sent: 123AA Idents called: 12300 -> 12399  
1000 Radios Ident Sent: 12AAA Idents called: 12000 -> 12999

### To send the Selcall Ident

With the required Selcall Ident displayed in the CALL TO mode, press and **hold** the **CALL** button for a few seconds until the radio beeps. The Selcall Ident will be sent automatically and the radio will return to normal operation.

### Call Acknowledge in Group Mode

There is no call acknowledge when sending group calls. This is to prevent all the radios in your group from trying to respond to your Selcall transmission at the same time.

### Storing Group Call Idents

Group Call Idents can be stored in memory in the same way as a standard Selcall Ident.

### Receiving Group Calls

Receiving a Group Call is identical to receiving a normal Selcall except that the alarm sound is a LOW tone beep instead of the normal HIGH tone beep. The Callers Ident or ALPHA Name appears on the display in the usual way.

## MENU SETTINGS

The MENU feature provides a convenient method of customizing or storing some of the radio's functions. The following Menu Options are available.

Menu Settings
Squelch
CTCSS / DCS
Backlight
Display Colour
S-Meter / Battery
Beep

### To access the Menu functions

1. Press and hold the **MENU** key. The first Menu function is displayed.
2. Briefly press the **MENU** key again to cycle through each available function in the order listed above. After the last function has been selected, the cycle returns to the beginning.
3. Press the **▲** or **▼** keys to alter the parameters of the selected function.
4. Press and hold the **MENU** key to exit and store any changes.

### SETTING THE SQUELCH SENSITIVITY

The sensitivity of the Squelch to incoming signals can be set to suit your operating environment. In quiet rural locations a low setting will allow the weakest signals to be received while still keeping the radio quiet between transmissions. In city locations, a higher setting might be needed to ensure the squelch remains closed when subjected to the higher interference levels often encountered in high density areas.

The TX3340 has nine (9) preset Squelch sensitivity settings (labelled SQL-1 to SQL-9) that can be selected using the Menu function. The minimum Squelch setting (SQL-1) is the most sensitive and will allow the Squelch to open on weak signals. SQL-9 is the maximum setting, requiring very strong signals to open the squelch. The factory default is SQL-3 which generally provides reliable Squelch operation for most applications.

### To pre-select the Squelch sensitivity

1. Select a Channel between 1 and 40.
2. Press and hold the **MENU** key until the radio beeps. SQL-x will be displayed where x is a number from 1 to 9.

3. Press the **▲** or **▼** keys increase or decrease the preset squelch to the desired setting.
4. Press and hold the **MENU** key to store the new setting.

### CTCSS & DCS

#### CTCSS (CONTINUOUS TONE CODED SQUELCH SYSTEM)

CTCSS is a squelch quieting system that allows several groups of users to share the same channel without disturbing each other. It uses one of a set of sub-audible (very low frequency) tones to open and close the squelch on your radio.

There are two CTCSS tone sets, one comprising 50 tones and the other comprising 38 tones. Both tone sets are installed in the TX3340 to ensure compatibility with other radio systems.

For more details, see **CTCSS Tone Frequency Chart** on page 19. To toggle between the CTCSS 50 tone set and the CTCSS 38 tone set:

1. Switch the radio off.
2. Press and hold the **SQL** key while switching the radio on again.
3. CTC50 or CTC38 will be displayed indicating which tone set has been selected.

**Note:** When switching from CTC38 to CTC50 the radio will retain the currently selected CTCSS tone but will update the associated tone set number to reflect its new location in the CTC50 tone set table.

e.g. CTCSS tone frequency of 233.6 Hz is tone #36 in the CTC38 tone set table but changes to tone #47 when CTC50 is selected.

When switching down from CTC50 to CTC38, if there is no equivalent CTC38 tone frequency the CTCSS tone will be set to **oF** and you will need to reselect a new tone.

#### DCS (DIGITALLY CODED SQUELCH)

DCS is a squelch quieting system similar to CTCSS, that uses low frequency digital signals instead of one continuous low frequency tone. As with CTCSS, it also allows several user groups to share the same channels without disturbing each other. There are 104 DCS codes available.

See **DCS Tone Chart** on page 20.

#### Selecting a CTCSS or DCS tone

Choosing which tone to use will probably be dependent on the other radios you talk to. If you talk to others outside your group who already use CTCSS or DCS tones, you will need to select the

tone set and frequency that matches theirs. The TX3340 includes most of the commonly used tone sets.

If the users you talk to don't currently use CTCSS or DCS you can make your own choice. There is no difference in performance or function between the different tone sets.

### To select a CTCSS or DCS tone

---

**Note:** When selecting tones, CTCSS tones are prefixed with 'CTC' and DCS tones are prefixed with 'DC'.

1. Press and hold the **MENU** key until the radio beeps.
2. Briefly press the **MENU** key repeatedly until 'CTCxx' or 'DCxxx' is displayed (where xx represents a tone number in the CTCSS/DCS Tone Frequency Chart).
3. Press the **▲** or **▼** keys to scroll through the tone list and select the required CTCSS or DCS tone. Scroll upwards for DCS tones and downwards for CTCSS tones.

If you wish to view the CTCSS frequency or DCS tone instead of the table number, briefly press the **PRI** key. To return to the table code briefly press the **PRI** key again or wait for it to time-out.

4. To disable CTCSS or DCS tones altogether scroll to the bottom of the list and select 'CTCoF'.
5. To store the setting, press and hold the **MENU** key until the radio beeps.

### BACKLIGHTING

---

Backlighting can be set to HIGH, LOW or OFF to satisfy your personal preference.

1. Press and hold the **MENU** key until the radio beeps.
2. Briefly press the **MENU** key repeatedly until 'LIGHT' is displayed.
3. Press the **▲** key to increase the backlight or the **▼** key to decrease the backlight.
4. Press and hold the **MENU** key until the radio beeps, to store the setting.

### DISPLAY COLOUR

---

The colour of the back light display can be changed to suit your installation environment.

To change the back light colour:

1. Press and hold the **MENU** key until the radio beeps.
2. Briefly press the **MENU** key repeatedly until 'COLOR' is displayed.

3. Press the **▲** or **▼** keys to cycle through Yellow, Red or Green back light colours.
4. Press and hold the **MENU** key until the radio beeps to store the settings.

### BATTERY / S-METER / ALPHA SELECTION

---

The TX3340 has the option of displaying either the battery voltage or the incoming signal strength (S-meter) in the area beneath the channel display.

#### To display S-Meter or Battery Voltage

---

1. Press and hold the **MENU** key until the radio beeps.
2. Briefly press the **MENU** key repeatedly until 'S-MET' (S Meter) or 'bATT' (Battery) is displayed.
3. Press the **▲** or **▼** keys to select your preferred choice of **S-MET** or **bATT**.
4. Press and hold the **MENU** key until the radio beeps, to store the setting.

### BEEP

---

To adjust the volume level of the keypad beeps:

1. Press and hold the **MENU** key until the radio beeps.
2. Briefly press the **MENU** key repeatedly until 'BEEP' is displayed.
3. Press the **▲** or **▼** keys to adjust the beep volume. The default setting is '3'.
4. To store the setting, press and hold the **MENU** key until the radio beeps.

## INSTALLATION

The TX3340 main unit is supplied with a slim, U-shaped mounting cradle. The cradle can be screwed or bolted in any convenient location in your vehicle (under or above the dash, on the centre console, etc.) using the mounting slots provided in the cradle. The TX3340 contains a built-in speaker, and should be installed in a convenient location in the vehicle's cabin as the radio's loud speaker. Alternatively it can be installed in a less audible location and an extension speaker used instead.

The LCD Controller Microphone comes complete with a mounting clip. Its small size and light weight design allows it to be mounted in almost any convenient position accessible to the driver.

When installing the radio, avoid mounting it close to heaters or air conditioners. Screw the LCD Controller Microphone's clip to a firm surface. Fit the TX3340 into the cradle and tighten the gimbal knobs. Place the LCD Controller Microphone in its mounting clip.

Finally, plug the LCD Controller Microphone into the front panel of the TX3340 and the power and antenna leads to the sockets provided on the rear of the radio.

## ANTENNA INSTALLATION

It is essential to select a good quality, high efficiency, 477 MHz antenna. A poor quality antenna or one not designed for the specific frequency band you are using will give very poor performance.

GME have a wide range of suitable 477 MHz UHF CB antennas to suit most installations and applications. We recommend contacting your local GME retailer for advice.

Connect to the antenna cable to the rear antenna socket using a PL259 coaxial connector.

## NOISE SUPPRESSION

The inherent design of FM transceivers result in a high level of resistance to ignition and electrical interference. However in some installations it may be necessary to take additional steps to help reduce or eliminate noise interference. During installation, try to route the DC battery leads, the antenna lead or any accessory wires away from the engine compartment, ignition or alternator wiring. If the noise continues, it may be necessary to fit a suppression kit in which case we recommend you consult an auto electrician for advice specific to your installation.

Higher frequency electrical interference cause by electric motors can be suppressed directly at the motor terminals.

## Fitting the LCD Controller Microphone

Slide Microphone into the mounting clip

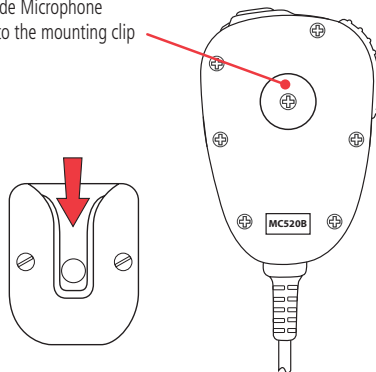

## Mounting the Cradle

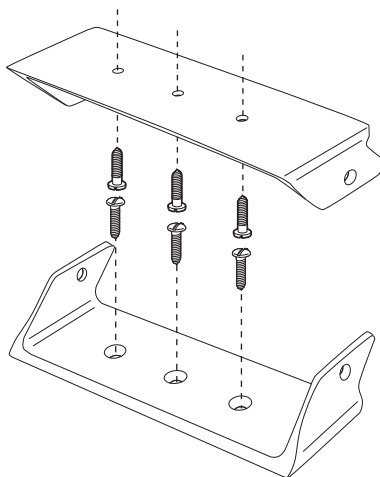

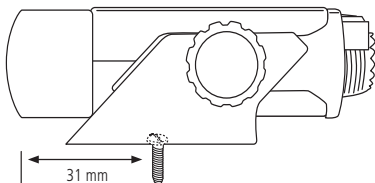
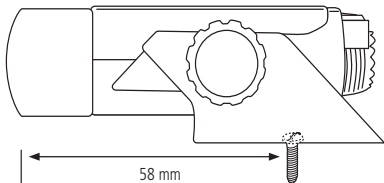

The mounting bracket can be oriented with the arms extending either forward or backwards to adjust the position of the front panel with reference to the mounting point.

### Fitting the Radio

Fit radio into cradle and tighten gimbal knobs.

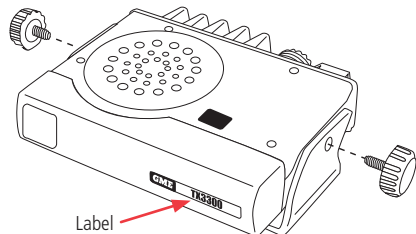

Once the orientation of your radio is confirmed, you can fit the GME model label. Simply remove the backing tape and press into the recess on the front panel.

### Fitting the Microphone

The microphone uses an 8 pin plug and socket.

To fit the microphone:

1. Position the microphone plug so the plastic tab faces downwards, and press the plug into the socket until it 'clicks'.
2. Gently slide the rubber boat towards the hole surrounding the socket until it is flush with the front panel.

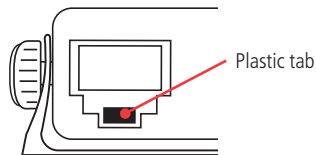

### Removing the Microphone

1. Slide the rubber boat back along the microphone cord.
2. Squeeze the plastic tab on the microphone plug towards the plug to unlock it while gently pulling the plug outwards. If the plug does not come out easily, the tab has not released correctly and should be squeezed again.

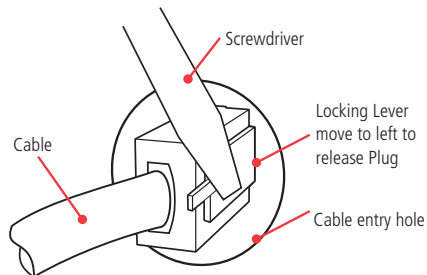

## DC POWER CONNECTION

The TX3340 is designed for 13.8 Volts DC, negative earth installations only (i.e. where the negative terminal of the battery is connected to the chassis or frame of the vehicle).

There are two recommended methods of installation.

### Radio remains ON when the ignition switch is OFF

Connect the radio's negative (black) lead to the vehicle's chassis, or if preferred, directly to the battery's negative terminal.

The radio's positive (red) lead should be connected via the 2 Amp fuse to the battery's positive terminal. Alternatively, the positive lead could be connected into the fuse box at a point that has +13.8 Volts continuously available (the battery side of the ignition switch) via the 2 Amp fuse.

### Radio turns OFF with the ignition switch:

Connect the radio's negative (black) lead to the vehicle's chassis, or if preferred, directly to the battery's negative terminal.

The radio's positive (red) lead should connect to an accessory point in the vehicle's fuse box via the 2 Amp fuse. This point should supply +13.8 Volts only when the ignition switch is turned ON or in the ACCESSORY position.

## HIGH VOLTAGE WARNING

The TX3340 has a built-in, high voltage detection system to warn you if an overvoltage situation occurs.

If the power supply voltage exceeds 18 Volts DC, the channel display will flash 'hi dc' for 5 seconds when the unit is first turned ON, or at the time the voltage exceeds 18 Volts. In addition, when transmitting, the TX indicator will flash and the transmitter will select low output power.

If the overvoltage warning appears you should switch your TX3340 OFF and disconnect it from the power source, before locating the cause of the trouble.

Once the high voltage warning has been triggered, and you have fixed the source of the problem, you will need to switch the TX3340 OFF then ON again to reset it.

The power source must not exceed 25 Volts otherwise permanent damage may occur to your radio, which may not be covered by the manufacturer's warranty.

## ANTENNA CONNECTION

GME supply a wide range of mobile and base station antennas designed specifically for UHF CB communications.

The antennas are fitted with a PL259 coaxial plug suitable for connection to the antenna socket on the rear panel of the radio.

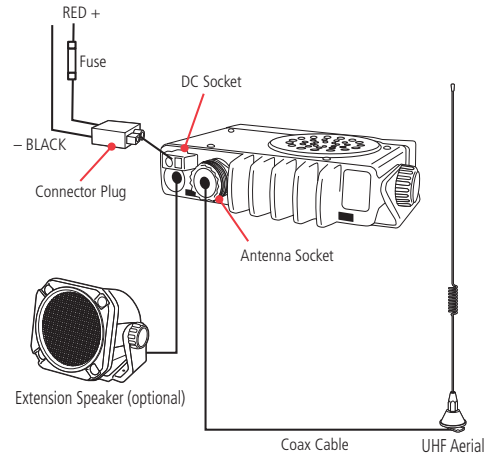
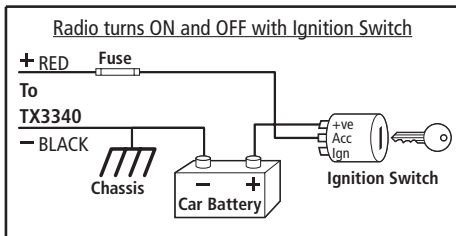
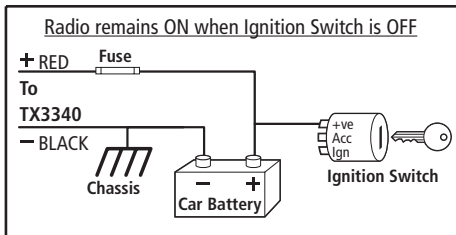

## CTCSS TONE FREQUENCY CHART

50 Tone Set	38 Tone Set	Frequency	50 Tone Set	38 Tone Set	Frequency	50 Tone Set	38 Tone Set	Frequency
1	1	67.0	18	17	118.8	35	-	183.5
2	-	69.4	19	18	123.0	36	30	186.2
3	2	71.9	20	19	127.3	37	-	189.9
4	3	74.4	21	20	131.8	38	31	192.8
5	4	77.0	22	21	136.5	39	-	196.6
6	5	79.7	23	22	141.3	40	-	199.5
7	6	82.5	24	23	146.2	41	32	203.5
8	7	85.4	25	24	151.4	42	-	206.5
9	8	88.5	26	25	156.7	43	33	210.7
10	9	91.5	27	-	159.8	44	34	218.1
11	10	94.8	28	26	162.2	45	35	225.7
12	11	97.4	29	-	165.5	46	-	229.1
13	12	100.0	30	27	167.9	47	36	233.6
14	13	103.5	31	-	171.3	48	37	241.8
15	14	107.2	32	28	173.8	49	38	250.3
16	15	110.9	33	-	177.3	50	-	254.1
17	16	114.8	34	29	179.9			

*CTCSS Frequency shown in Hz*

## DCS TONE CHART

DCS	CODE	DCS	CODE	DCS	CODE	DCS	CODE	DCS	CODE	DCS	CODE
1	023	19	116	37	225	55	325	73	452	91	627
2	025	20	122	38	226	56	331	74	454	92	631
3	026	21	125	39	243	57	332	75	455	93	632
4	031	22	131	40	244	58	343	76	462	94	654
5	032	23	132	41	245	59	346	77	464	95	662
6	036	24	134	42	246	60	351	78	465	96	664
7	043	25	143	43	251	61	356	79	466	97	703
8	047	26	145	44	252	62	364	80	503	98	712
9	051	27	152	45	255	63	365	81	506	99	723
10	053	28	155	46	261	64	371	82	516	100	731
11	054	29	156	47	263	65	411	83	523	101	732
12	065	30	162	48	265	66	412	84	526	102	734
13	071	31	165	49	266	67	413	85	532	103	743
14	072	32	172	50	271	68	423	86	546	104	754
15	073	33	174	51	274	69	431	87	565		
16	074	34	205	52	306	70	432	88	606		
17	114	35	212	53	311	71	445	89	612		
18	115	36	223	54	315	72	446	90	624		

## UHF CB OPERATING FREQUENCIES

Channel	Frequency (MHz)	Channel	Frequency (MHz)	Channel	Frequency (MHz)	Channel	Frequency (MHz)
1	476.425 ~	11 <sup>+</sup>	476.675	21	476.925	31	477.175 ~
2	476.450 ~	12	476.700	22 <sup>#</sup>	476.950	32	477.200 ~
3	476.475 ~	13	476.725	23 <sup>#</sup>	476.975	33	477.225 ~
4	476.500 ~	14	476.750	24	477.000	34	477.250 ~
5 <sup>*</sup>	476.525 ~	15	476.775	25	477.025	35 <sup>*</sup>	477.275 ~
6	476.550 ~	16	476.990	26	477.050	36	477.300 ~
7	476.575 ~	17	476.825	27	477.075	37	477.325 ~
8	476.600 ~	18	476.850	28	477.100	38	477.350 ~
9	476.625	19	476.875	29	477.125	39	477.375
10	476.650	20	476.900	30	477.150	40 <sup>^</sup>	477.400

- \* Emergency use only  
 + Officially Designated Call Channel  
 # Telemetry/Selcall use only. Voice Transmission is inhibited as required by AS/NZS 4365.2002  
 ^ Road Channel  
 ~ Repeater Channels

## SPECIFICATIONS\*

### ENVIRONMENTAL

---

Temperature Range: -10°C to +60°C

### ELECTRICAL

---

#### GENERAL

---

Compliant Specification: AS/NZS 4365  
Frequency Range: 476.425-477.4 MHz  
Number of Channels: 40 UHF CB  
Channel Spacing: 25 kHz  
Operation Mode: Simplex channels 1-40  
Semi Duplex channels 1-8.  
Scanning Speed: 20 channels per second  
Antenna Impedance: 50 Ohms nominal  
Operating Voltage Range: 10-15 Volts DC  
Nominal Battery Voltage: 13.8 Volts DC  
Over Voltage Protection: 25 Volts DC max. At 18 Volts DC the RF power is reduced, and the words 'Hi DC' flash.  
Over Current Protection: In-line 2A Fuse  
Reverse Polarity Protection: Shunt Diode  
Frequency Stability:  $\pm 5$  PPM  
Selcall Tone Length: 40 ms

#### Transmitter

---

RF Output: 5.0 Watts max.  
Modulation: FM  
Maximum Deviation:  $\leq \pm 5$  kHz at + 20 dB limiting  
Spurious Emissions:  $< -70$  dBc  
Transmit Frequency  
Response: + 6 dB per octave  
300 Hz to 3 kHz + 1-3 dB.  
Audio Signal to Noise:  $> 45$  dB  
Current Consumption: 1.5 Amps with 50 Ohm termination

#### Receiver

---

Circuit Type: Double Conversion Superheterodyne  
Intermediate Frequencies: 1st - 21.4 MHz  
2nd - 450 kHz  
Current Consumption:  $< 180$  mA muted  
600 mA @ max. A.F output  
Sensitivity: - 123 dBm for 12 dB SINAD unweighted  
Selectivity: - 6 dB at + 7.5 kHz  
- 70 dB at  $\pm 25$  kHz  
Intermodulation Immunity: 73 dB  
Blocking Immunity: 100 dB  
Spurious Response  
Immunity: 70 dB  
Audio Power: 3 Watts average into 4 Ohms  
Audio Signal to Noise:  $> 45$  dB  
Receive Frequency  
Response: - 6 dB/Octave de-emphasis  
300 Hz to 3 kHz + 1-3 dB  
Conducted Spurious  
Emission:  $< -57$  dBm

#### MECHANICAL

---

Dimensions: 102 (W) x 87 (D) x 23 (H) mm  
Weight: 158 grams  
Shock and Vibration: MIL STD 810 method

---

\*Specifications are typical unless otherwise indicated and may be subject to change without notice or obligation.

## STANDARD COMMUNICATIONS CONTRACT WARRANTY

### I. STATUTORY WARRANTIES

- 1.1 The Trade Practices Act Part V, Division 2A and other legislation imply conditions, warranties and other obligations on us to consumers that cannot be excluded, restricted or modified. Those provisions apply to the extent required by law.
- 1.2 We exclude all other conditions, warranties and obligations which would otherwise be implied concerning the activities covered by this agreement.
- 1.3 We limit our liability where we are allowed to do so. Examples of where we are allowed to limit liability are -
  - (a) you acquire goods from us for re-supply;
  - (b) the goods or services we supply are not of a kind ordinarily acquired for personal, domestic or household use or consumption.
- 1.4 Where we are allowed to limit our liability, to the extent permitted by law, our sole liability for breach of a condition, warranty or other obligation implied by law is limited -
  - (a) in the case of goods we supply, to any one of the following as we decide -
    - (i) the replacement of the goods or the supply of equivalent goods;
    - (ii) the repair of the goods;
    - (iii) the payment of the cost of repairing the goods or of acquiring equivalent goods;
    - (iv) the payment of the cost of having the goods repaired; or
  - (b) in the case of services we supply, to any one of the following as we decide -
    - (i) the supplying of the services again;
    - (ii) the payment of the cost of having the services supplied again.

### 2. ADDITIONAL WARRANTIES

- 2.1 The warranties in this clause are in addition to the statutory warranties referred to in the previous clause.
- 2.2 We warrant our goods to be free from defects in materials and workmanship for three years from the date of original sale (or another period we agree to in writing). During this period and as our sole liability to you under this warranty, we agree to, at our option, either repair or replace goods which we are satisfied are defective. We warrant replacement parts for the remainder of the period of warranty for the goods into which they are incorporated.

- 2.3 We warrant our other repairs to be free from defects in materials and workmanship for three months from the date of the original repair. During this period and as our sole liability to you for the repair, we agree to repair or replace (at our option) repaired goods which we are satisfied are defective.
- 2.4 We warrant that we will perform services with reasonable care and skill and agree to investigate any complaint made in good faith that we have performed services unsatisfactorily. If we are satisfied that the complaint is justified, and as our sole liability to you under this warranty, we agree to supply those services again at no extra charge to you.
- 2.5 If you want warranty under this clause you must give us an original or copy of the sales invoice from the transaction or some other evidence showing details of the transaction.

### 3. OTHER LIMITATIONS

- 3.1 You may not rely on any representation, warranty or other provision by or for us which is not covered by clause [ 1 ] or repeated in this agreement in clear terms.
- 3.2 We are not liable (nor are our employees, contractors and agents) for any damage, economic loss or loss of profits whether direct, indirect, general, special or consequential -
  - (a) arising out of any breach of any implied or express term, condition or warranty; or
  - (b) suffered as a result of our negligence (or that of our employees, contractors or agents) - apart from liability as set out in the previous two clauses.
- 3.3 The liability of a party under this agreement (whether arising in contract, tort or by statute) is to be reduced by the same proportion as represents the proportion of the loss or damage caused or contributed to by the other party, its contractors or agents.

### GME AFTER SALES SERVICE

Your GME TX3340 is especially designed for the environment encountered in mobile applications. The use of all solid state circuitry, careful design and rigorous testing, result in high reliability. Should failure occur however, GME maintain a fully equipped service facility and spare parts stock to meet the customer's requirements long after expiry of the warranty period.



A Division of: **Standard Communications Pty. Ltd.**



Authorised Dealer:

[www.cimconcepts.com.au](http://www.cimconcepts.com.au)

**CIM**  **concepts**

The word 'CIM' is in a large, bold, black sans-serif font. To its right is a graphic of three overlapping, wavy lines in red, blue, and yellow. The word 'concepts' is in a smaller, grey, lowercase sans-serif font.

Communication & Information on the Move

---

[www.cimconcepts.com.au](http://www.cimconcepts.com.au)

Ph 03 8802 0387